

CNC Ball Valve Grinding Machine



SMG32H

- This model is rigid and high accuracy for small size spherical surface;
- Closed column, triangular tailstock and bracket structure ensure the overall rigidity of the bed;
- The workpiece is tight by servo-driven, the layout is reasonable and advanced, the machine tool has good rigidity, easy to operation;
- This machine is suitable for grinding of 75-320mm size ball.



Structure Layout:

- The forward and backward movement of the column- Z-axis
- The headstock moves up and down -Y-axis
- The tailstock moves up and down- V-axis movement (servo control)
- The rotary motion of the table- B axis

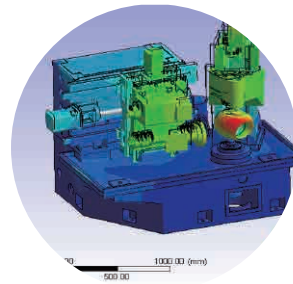

Ball Grinding Range:

SΦ75-320mm

Max. Workpiece Weight:

350kg

Grinding Accuracy:

Roundness at sealing round cross section
≤0.008mm

Surface Roughness:

Ra≤0.4um



SMG63HA

Utility model patents:

High rigidity compact machine tool base structure

Patent Number: 201120517142.7

- This model adopts the "Fan Cheng" grinding method;
- adopts vertical clamping;
- Modular design, spherical diameter grinding from 320-630mm;
- This machine is suitable for grinding of 75-320mm size ball;
- Machine statics and modal analysis to ensure the overall static stiffness and dynamic characteristics of the machine;
- Easy operation, easy to access to the workpiece and spindle.



Structure Layout:

The Left and right movement of the column- Z-axis

The headstock moves up and down -Y-axis

The tailstock moves up and down- V-axis movement (servo drive)

The rotary motion of the table- B axis

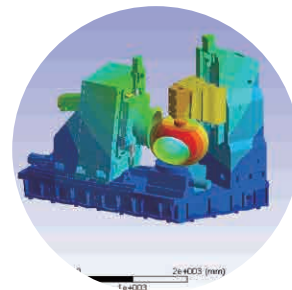

Ball Grinding Range:

SΦ320-630mm

Max. Workpiece Weight:

800kg

Grinding Accuracy:

Roundness at sealing round cross section
 $\leq 0.010\text{mm}$

Surface Roughness:

$Ra \leq 0.4\mu\text{m}$

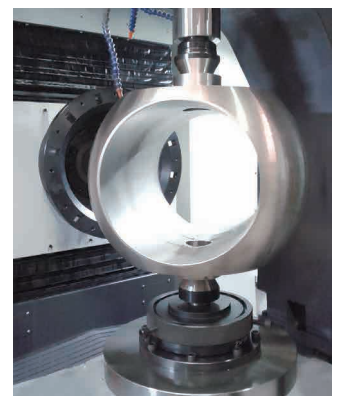

SMG100H

Utility model patents:

Radial adjustable device for center position of center

Patent Number: ZL2018 2 1314137.4

- This model adopts the vertical clamping of the sphere to avoid the Deformation caused by gravity due to horizontal clamping;
- High-power, high-precision grinding spindle unit and precision CNC rotarytable to ensure the high precision of the whole machine;
- Standard equipped with mist suction device, high-precision rotary table, double top positioning fixture.

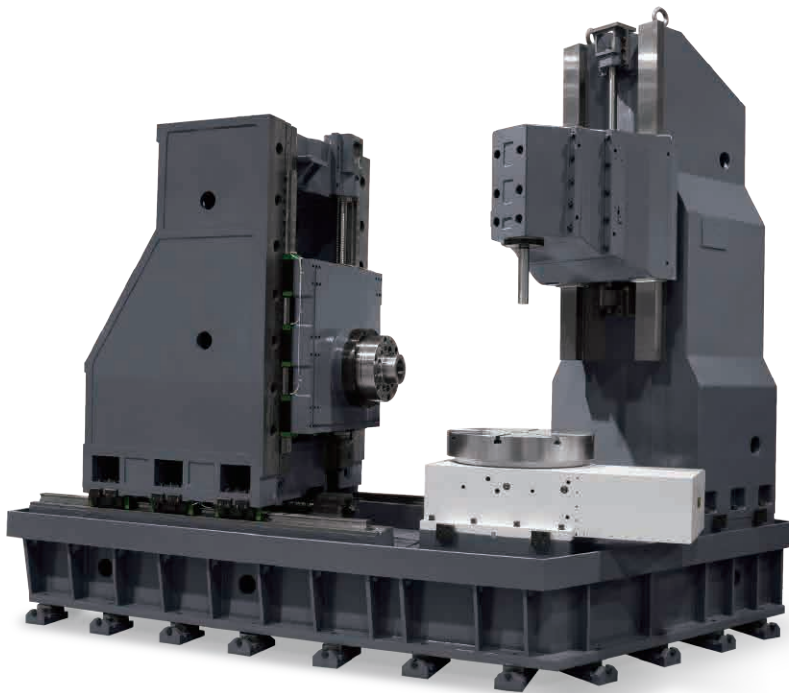

Structure Layout:

The left and right movement of the carriage -Z axis

The slide and the headstock -Y-axis

The tailstock move moment -V-axis .

The rotary motion of the table- B axis.

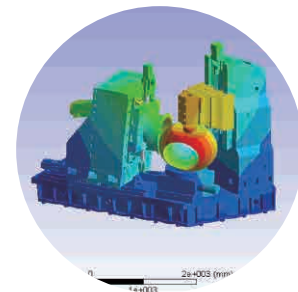

Ball Grinding Range:

SΦ630-1100mm

Max. Workpiece Weight:

3500kg

Grinding Accuracy:

Roundness at sealing round cross section
 $\leq 0.015\text{mm}$

Surface Roughness:

$Ra \leq 0.4\mu\text{m}$

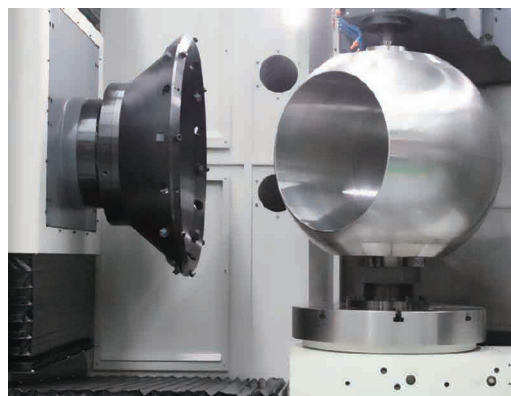

SMG240H

- This model adopts L-shaped bed, closed column, triangular tailstock and stepped bracket to ensure the overall rigidity and compact structure of the bed;
- Y-axis with hydraulic lock;
- V-axis with hydraulic lock;
- Workpiece is tight by hydraulic cylinder , and the pressure is adjusted according to the size of the sphere;
- Easy to operate.

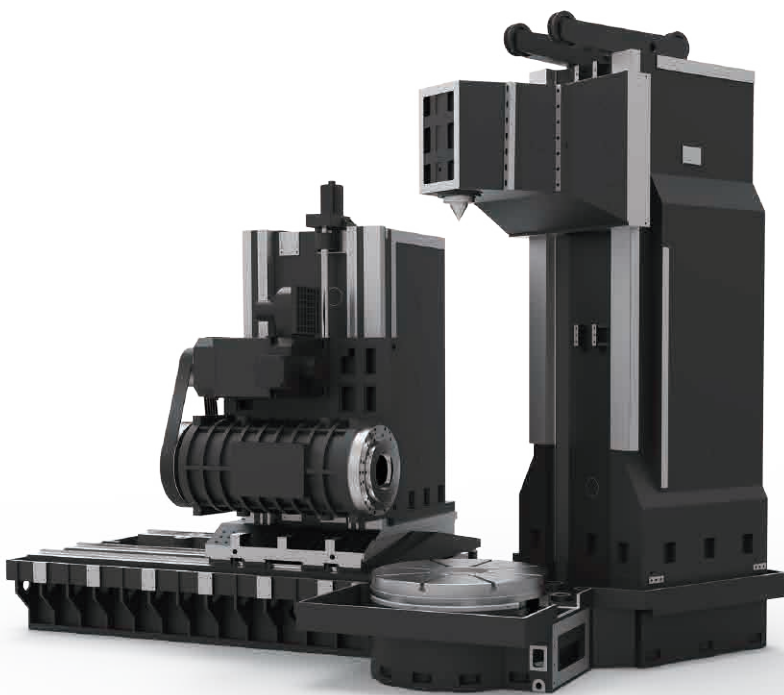

Structure Layout:

- The forward and backward movement of the column-Z-axis
- The headstock moves up and down -Y-axis
- The tailstock moves up and down- V-axis movement (servo control)
- The rotary motion of the table- B axis.

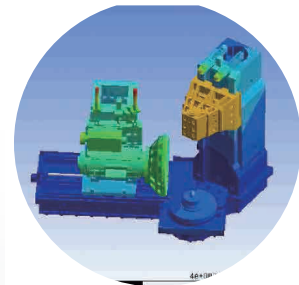

Ball Grinding Range:

SΦ900-2400mm

Max. Workpiece Weight:

25000kg

Grinding Accuracy:

Roundness at sealing round cross section $\leq 0.025\text{mm}$ (24" ~ 40")

Roundness at sealing round cross section $\leq 0.035\text{mm}$ (42" ~ 64")

Surface Roughness:

$Ra \leq 0.4\mu\text{m}$



Grinding Stone	Abrasive	The ball material
	Carborundum	Carbon steel/Stainless steel
	Cubic boron nitride	Ni-based coating
	Synthetic diamond	Tungsten DLC Coating

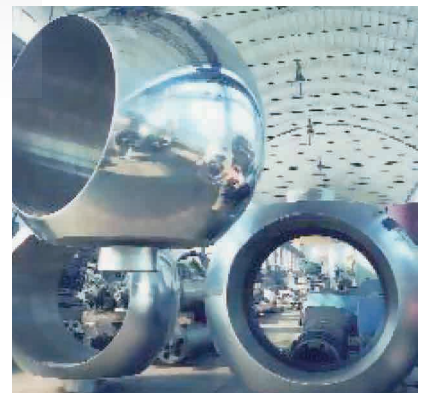

Parameter

Item		Unit	SMG32H	SMG63HA	SMG100H	SMG240H
Capacity	Machining sphere outside diameter range	mm	SΦ75~320	SΦ320~630	SΦ630-1100	SΦ900-2400
	Hole diameter in machined sphere	inch	2"~8"	8"~16"	16"~28"	24"~64"
Grinding wheel spindle	Motor power	kW	15	15/18.5	28	80
	Rated torque	N.m	96	98	267	1910
	Max. spindle speed	rpm	6000	2000	1500	500
Workpiece spindle	Motor power	Kw	3.7	5.5	7.5	55
	Rated torque	N.m	24	36	49	709.8
	Max. spindle speed	rpm	60	30	15	10
Travel	Y/Z	mm	200/500	200/500	400/900	800/2000
Rapid travel speed	Y/Z	m/min	18/20	12/20	16/16	6/4
Accuracy	Positioning accuracy (Y/Z)	mm	0.008/0.008	0.008/0.008	0.011/0.016	0.020/0.016
	Repeatability accuracy (Y/Z)	mm	0.004/0.004	0.004/0.004	0.006/0.009	0.012/0.009
Other	CNC system	-	SIEMENS 828D/FANUC Oi-TF(G)			SIEMENS 828D
	Machine weight	kg	6000	7500	22000	85000

External Dimensions

(Unit: mm)

SMG32H

